



Installation Guide & User Manual

SoundPlus® WIR TX800 Two Channel Infrared System

Large Area Infrared Listening System

Modulator Model MOD 112
Emitter Model WIR TX8
Receiver Models WIR RX5, RX6





SOUNDPLUS® WIR TX800 INFRARED LISTENING SYSTEM, TWO-CHANNEL INFRARED LISTENING SYSTEM

INSTALLATION GUIDE AND USER MANUAL

Contents	Page
SYSTEM OVERVIEW	4
INSTALLATION PROCEDURES	6
STEP 1: TX8 EMITTER SETUP	
STEP 2: TX8 POWER WIRING	
STEP 3: BASEBAND CABLE CONNECTION	
STEP 4: MOD 112 MODULATOR SETUP	
STEP 5: TESTING THE SYSTEM	
CONTROLS AND FEATURES	14
MOD 112 FRONT PANEL	
MOD 112 REAR PANEL	
TX8 EMITTER REAR PANEL	
RECEIVER INSTRUCTIONS	19
TROUBLESHOOTING	21
WARRANTY	22
SPECIFICATIONS	23

NOTE: TAKING A FEW MINUTES NOW TO READ THESE INSTRUCTIONS WILL SAVE TIME AND ENSURE PROPER SYSTEM OPERATION.



SYSTEM OVERVIEW

The Williams Sound WIR TX800 System consists of a MOD 112 Modulator and one or more TX8 Emitters which use invisible infrared (IR) light waves to broadcast speech or music to wireless infrared receivers.

The MOD 112 accepts a variety of audio inputs and sends 95 kHz and 250 kHz frequency modulated signals to the TX8 Emitter via coaxial cable. The emitter emits invisible infrared light into the listening area. Infrared receivers detect the transmission and convert the light signals back into audio signals.

The system is designed to transmit high quality audio for hearing assistance and language translation applications. Because the system uses infrared light for transmission, it is not affected by interference from radio equipment and does not interfere with radio equipment. No FCC license is required.

The TX8 Emitter is designed to distribute its power equally among the channels sent to it for transmission. Thus, when only a single channel is present, the TX8 uses all its power to broadcast the lone signal, achieving a coverage area of approximately 10,000 square feet (930 square meters). When two signals are sent to the TX8 (as is the case when the MOD 112 is in Stereo mode or in Discrete mode when both channels are in use), the TX8 divides its power among the two signals. This makes for a practical coverage area of about 3,767 square feet (350 square meters). This important principle is illustrated in Figure 3. Larger areas can be covered with additional emitters.

The system can be used with a microphone as a stand-alone system, or can be connected to an existing sound system. Infrared Systems cannot be used in bright sunlight because of sunlight's large amount of interfering infrared light.

FIGURE 1A: TYPICAL SYSTEM CONFIGURATIONS

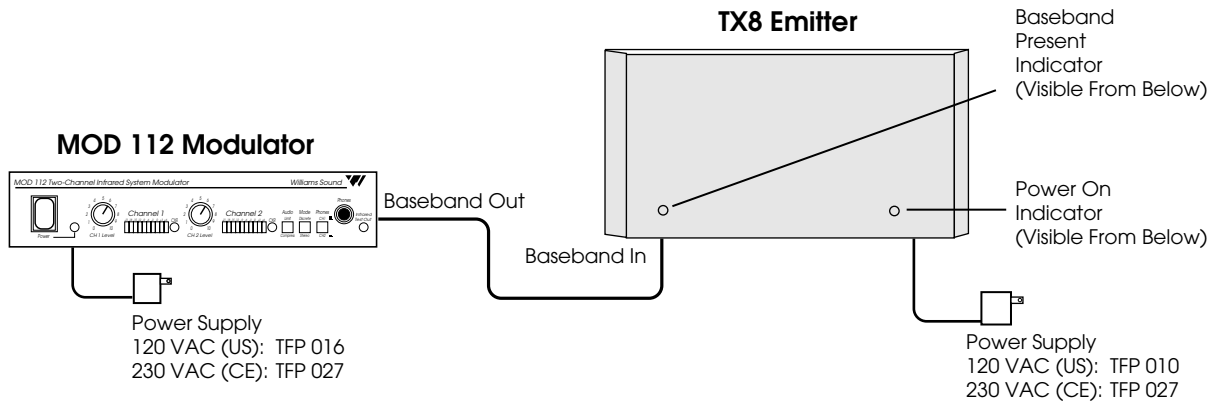
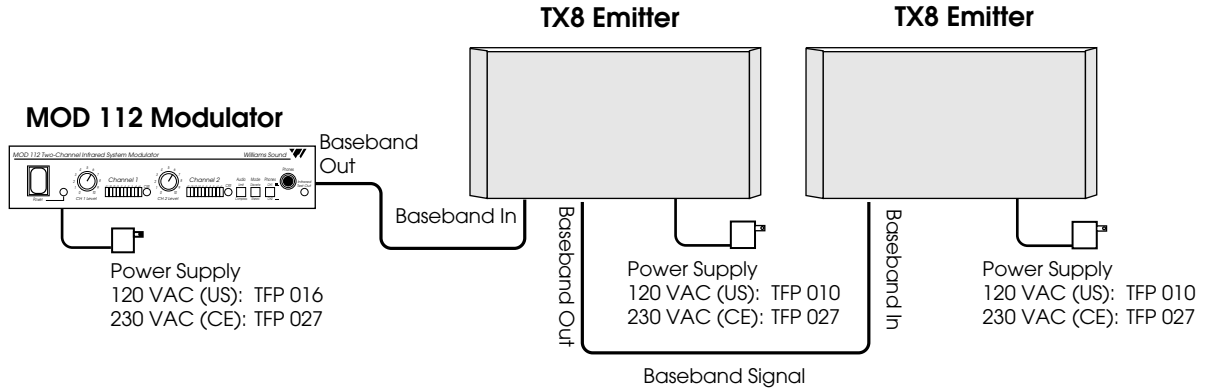

FIGURE 1B: USING AN ADDITIONAL TX8 EMITTER FOR GREATER COVERAGE AREA.



INSTALLATION PROCEDURE

INSTALLATION STEP 1: TX8 EMITTER SET-UP

SELECTING A MOUNTING LOCATION

The most important principle to understand when installing the TX800 system is that invisible infrared light behaves just like visible light. It does not pass through opaque objects such as walls, curtains, or people. It does pass through windows and door openings and can bounce and scatter off reflective walls, floors, and ceilings. Therefore, the infrared emitter panels should not be concealed or covered, nor should the infrared “eye” on receiver units be covered. Receivers work best with a clear line-of-sight to the emitter panels.

The TX8 Infrared Emitter should not be installed outdoors, or where there is a lot of direct sunlight indoors. Sunlight generates infrared interference. Certain types of high-efficiency lighting fixtures can also generate interference at 95 kHz because they use high frequency modulation.

FIG. 2A: BRACKET 024 MOUNTING

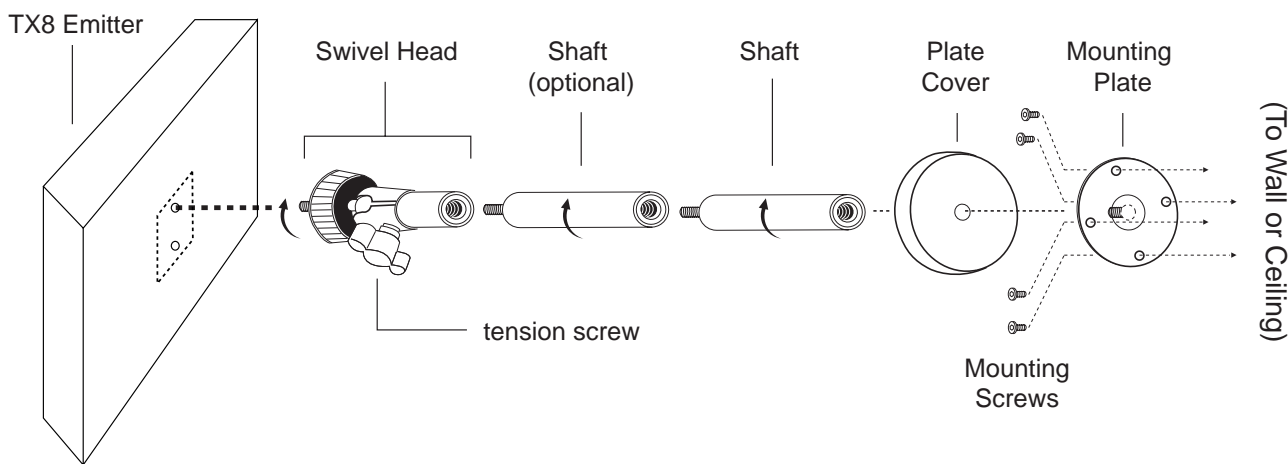

MOUNTING THE TX8 TO A WALL OR CEILING:

- Step 1:** Using the mounting plate (Figure 2A) as a template, mark the hole locations on the mounting surface where the TX8 will be installed. See Page 7, Figure 2B for optional mounting positions.
- Step 2:** Locate the top mounting hole in the rear of the TX8 emitter. Gently screw the male end of the swivel head on to the emitter. Tighten the swivel head *tension screw*: turn clockwise until the connection is secure.
- Step 3:** Screw the male end of the shaft into the female end of the swivel head. An additional shaft can be added to create more distance between the wall/ceiling and Emitter.
- Step 4:** Place the plate cover snugly over the mounting plate. This will hide the screws after installation.
- Step 5:** Screw the male end of the mounting plate into the female end of the shaft. *For suspended ceilings*, screw the female end of the shaft into the male end of the *T-Bar clip*. The mounting bracket is now installed on to the TX8 Emitter.
- Step 6:** Position the TX8 Emitter and BKT 024 so the mounting plate lines up with the marked holes on the mounting surface. Fasten the mounting plate to the surface using screws and wall anchors. *Mounting the TX8 to a Suspended Ceiling with Cross Tee:* Fasten the T-Bar clip on to the desired Cross Tee.
- Step 7:** Position the TX8 Emitter to the desired angle: Begin by gently turning the tension screw (Figure 2A) counter clockwise to release the swivel head. Adjust the TX8 to the desired angle. When the TX8 is in the desired position, gently turn the tension screw clockwise until the swivel head is securely in place.

FIG. 2B: WALL OR CEILING MOUNT

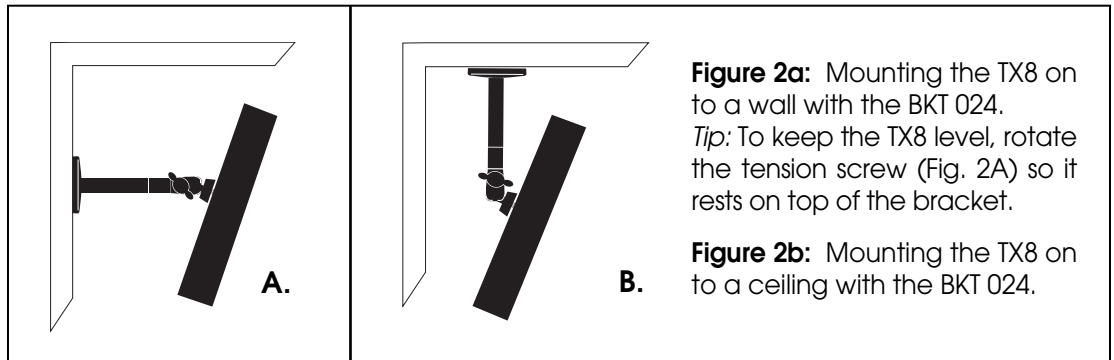

ILLUMINATION PATTERNS

The infrared illumination pattern from a single emitter is cone-shaped, with a 50° angle. The horizontal and vertical patterns are identical. Figures 3, 4, and 5 show top and side views of coverage patterns.

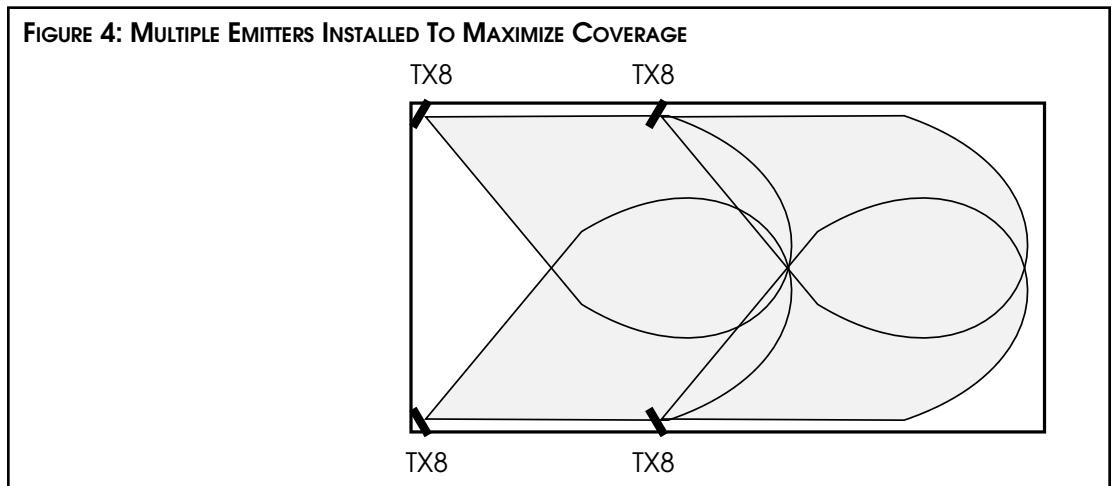
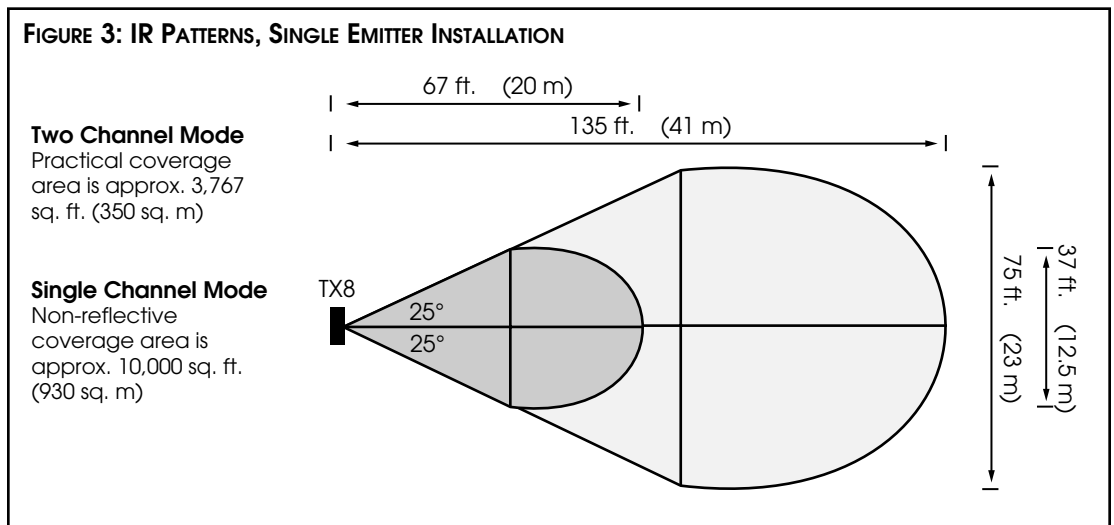

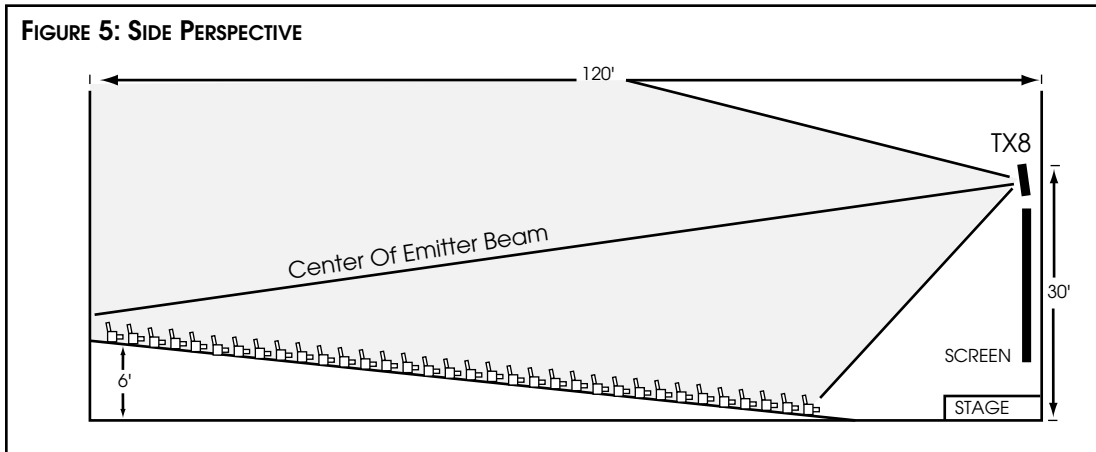

These patterns are the direct radiation pattern. The infrared radiation does not drop to zero outside the illustrated patterns; it decreases. It still may be useable at a greater distance, depending on receiver sensitivity and the reflection characteristics of the room.

Infrared light reflects off most surfaces and scatters, increasing the coverage area. Rough surfaces tend to absorb infrared light, minimizing reflections, and limiting coverage to the direct illumination pattern.

It's helpful to think of the IR emitter as an invisible floodlight. You want to aim it so listeners are "flooded" with infrared light.

It's desirable for the illumination patterns to overlap when multiple emitters are used. Placing the emitters high above the audience (15–30 ft./4-8m) and aiming them slightly downward (5°–15°) will ensure the longest "throw" of the infrared beam. Angling the emitter inward towards the center of the room also increases the coverage of the seating area.

Remember: opaque objects block infrared light. Thus, emitters cannot be concealed behind opaque walls, curtains, etc. Neither should emitters be used in areas of extreme high or low temperatures, humidity, or chemical environments.

COVERAGE AREA

The TX8 Emitter is designed to distribute its power equally among the channels sent to it for transmission. Thus, when only a single channel is present, the TX8 uses all its power to broadcast the lone signal, achieving a coverage area of approximately 10,000 square feet (930 square meters). When two signals are sent to the TX8 (as is the case when the MOD 112 is in Stereo mode or in Discrete mode when both channels are in use), the TX8 divides its power among the two signals. This makes for a practical coverage area of about 3,767 square feet (350 square meters) or about 350 average theater seats. This important principle is illustrated in Figure 3.

If you're not getting sufficient coverage with a single, properly installed emitter panel, you'll need to add additional TX8 Emitters to achieve full coverage of your listening area.

Figures 3, 4, and 5 illustrate infrared light patterns and recommended emitter locations. In listening areas up to 3,767 square feet (350 sq. m.) , the TX8 Emitter panel should be installed on the front wall of the listening area in a position to flood the listening area. It must be above the audience to permit a direct line of sight between the emitter and people wearing receivers when the people are standing or sitting.

Listening areas of more than 3,767 square feet (350 sq. m.) will require two or more TX8 Emitters for complete coverage. Place one emitter panel on the left side of the front wall and the other on the right hand side. For extremely large venues, additional TX8s should be located to maximize coverage throughout the listening area.

INSTALLATION STEP 2: TX8 POWER WIRING

FOR U.S. APPLICATIONS:

The TX8 Emitter is supplied with a low-voltage wall transformer power supply (TFP 010). Two-conductor 18 ga. power cord is included with the emitter.

FOR APPLICATIONS OUTSIDE THE U.S. REQUIRING 240 VAC MAINS SUPPLY:

Use the wall transformer power supply, model TFP 027.
Secondary Specifications: **24 VAC, 35 VA, 50/60 Hz.**

!! IMPORTANT WARNING !!

SHORTING THE POWER SUPPLY OUTPUT TERMINALS WILL BLOW A NON-REPLACEABLE INTERNAL FUSE, DESTROYING THE POWER SUPPLY UNIT!

WARNING: POWERLINE VOLTAGE MUST NOT FALL BELOW 94V, OR SYSTEM PERFORMANCE WILL BE GREATLY REDUCED!

DO NOT CONNECT THE POWER SUPPLY TO AC POWER YET!!!

Step 1: Determine the length of power cord needed to reach from the transmitter to the AC wall outlet where the power supply will be plugged in. If power cord length will exceed 200 feet (61 m), heavier gauge wire will be required. Use the table below. **Make sure the power supply is not plugged into AC power yet!**

<u>Cable Length Required</u>	<u>Minimum Wire Gauge</u>
Up to 10 feet (3 m)	22 gauge
Up to 5 feet (23 m)	20 gauge
Up to 200 feet (61 m)	18 gauge
Up to 500 feet (152 m)	16 gauge
Up to 1,000 feet (305 m)	14 gauge

One end of the power cord has a 3-pin Molex connector, the other end is bare. Cut the bare end of the power cord to length. Strip this end down the middle approximately

1 inch, then strip both of the resulting strands about 1/8 inch. Install the crimp-on spade terminals supplied and connect these to the screw terminals on the Power Supply (TFP 010). Polarity is not important since AC power is being used.

Step 2: Plug the 3-pin Molex connector into the TX8's Power In connector.

Step 4: **Plug in the Power Supply last.**

The Power Indicator LED on the right side of the bottom panel (visible from directly underneath) glows when the TX8 is on.

Note: The TX8 transmits when an audio signal is present, and will shut off when no signal is present for about 30 minutes. This auto shut-off feature preserves the life of the infrared LEDs and reduces power consumption.

This system is designed for Class 2, low-voltage wiring. Always follow local electrical codes when doing low voltage wiring.

INSTALLATION STEP 3: BASEBAND CABLE CONNECTION

IF YOU ARE USING ONE EMITTER:

- Step 1: Determine the length of RG-58 coaxial cable needed to reach from the emitter to the modulator unit. The modulator is usually located with the other sound equipment to simplify audio connections. 100 feet (30 m) of coaxial cable is included with each emitter. You will need to cut it to length. Additional RG-58 coax can be added. Make sure you leave some slack at each end.
- Step 2: Install BNC connectors on each end of the cable. (See Figure 7.)
- Step 3: Connect the Baseband cable to the Baseband Out jack on the MOD 112 modulator and to the Baseband In jack on the TX8 Emitter. (See Figures 6 and 8.)

IF YOU ARE USING MORE THAN ONE EMITTER:

- Step 1: Determine the length of coaxial cable needed to reach between the emitters. 100 feet (30 m) of coaxial cable is included with each emitter. You will need to cut it to length. Additional RG-58 coax can be added. Make sure you leave some slack at each end.
- Step 2: Install BNC connectors on each end of the cable. (See Figure 7.)
- Step 3: Connect the baseband cable from the Baseband Out Jack on the first emitter in the chain (the one connected to the MOD 112 Modulator) to the Baseband In jack on the next TX8 Emitter in the chain. Use the cable clamps and screws provided to secure the cable. The coax can also be routed through conduit before attaching BNC connectors. You can chain as many emitters together as you need. Remember that each emitter needs its own TFP 010 power supply.

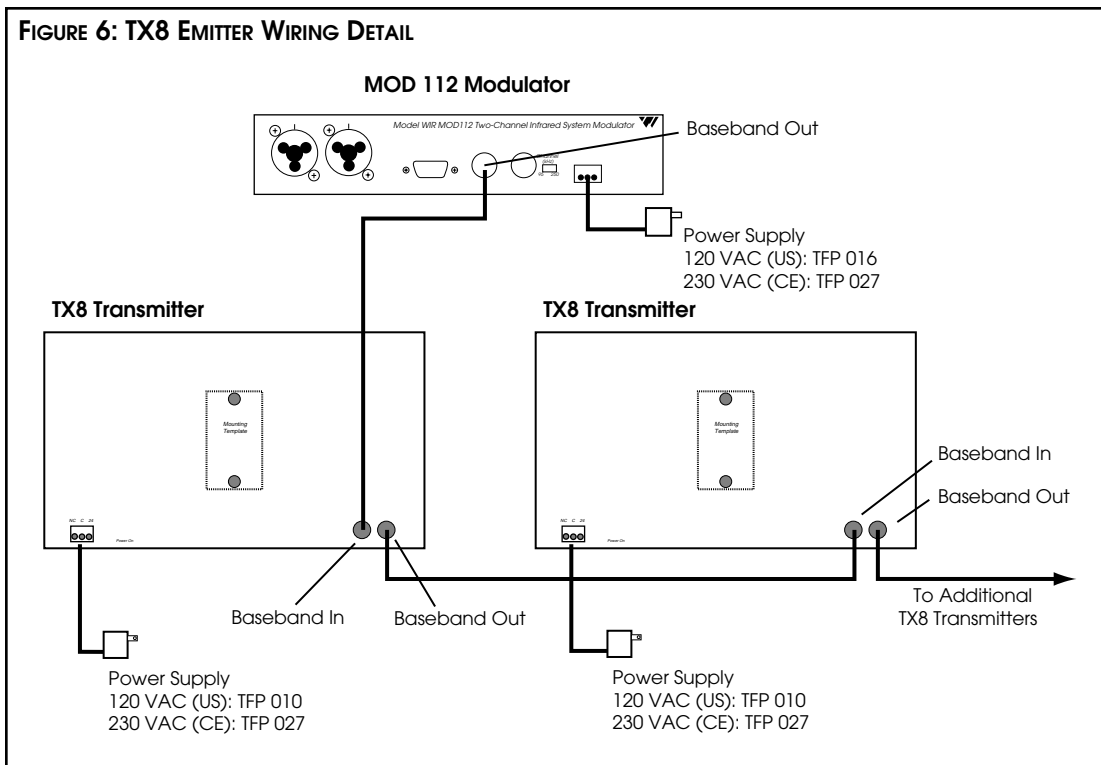
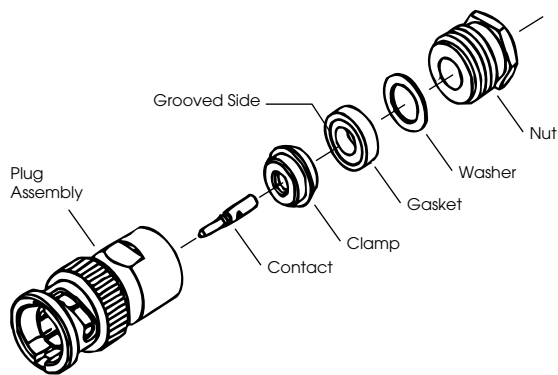

FIGURE 7: BNC CONNECTOR ASSEMBLY



ASSEMBLY PROCEDURE

The BNC Connector consists of a plug assembly, a contact, a clamp, a gasket, a washer, and a nut.

1. Slide nut, washer and gasket over cable end; then strip outer cable jacket using the recommended strip-length dimension in fig. 7b.
 2. Slide clamp over cable braid and position it against the cable jacket. After clamp is properly positioned, comb out the braid.
 3. Fold cable braid over the clamp and trim it so that it is positioned against the clamp collar. See figures 7c and 7d.
 4. Using the dimension in figure 7e, strip dielectric to expose the center conductor. If applicable, tin the center conductor.
 5. Solder contact to the conductor (using standard soldering techniques), making sure contact is bottomed on cable dielectric. See figure 7f.
- DO NOT allow a hot soldering iron to touch cable dielectric. Certain cable dielectric materials, such as polypropylene, will expand if they come in contact with a hot soldering iron.
6. Insert contact into plug assembly until contact snaps into place. See figure 7g.
 7. Thread nut into plug assembly until it is secured. Recommended cable clamp tightening torque is 2.8–3.4 N•m [25-30 in.-lb.], using a 7/16" wrench. See figure 7h.

7B

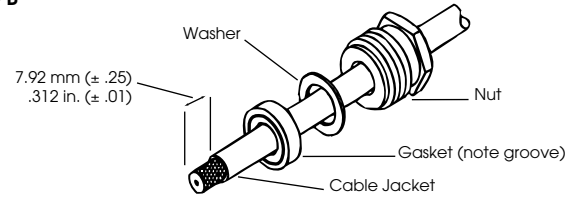

7C

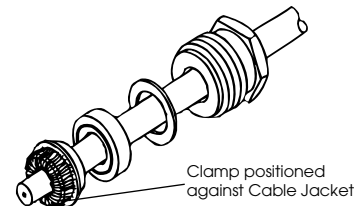

7D

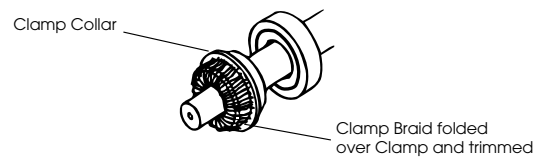

7E

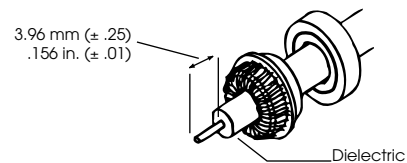

7F

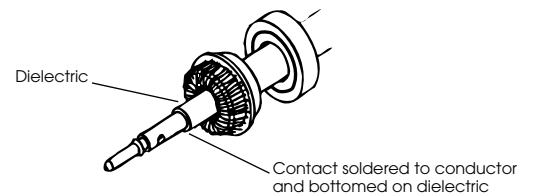

7G

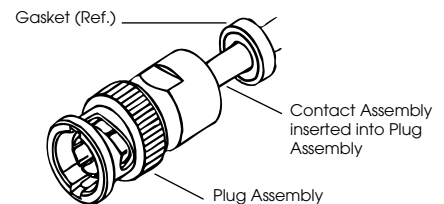

7H

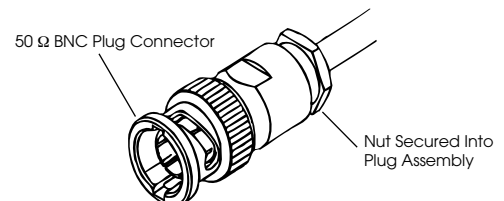

INSTALLATION STEP 4: MOD 112 MODULATOR SETUP

LOCATION

The Modulator is usually located with the sound system amplifier or mixer for easy access to an audio input signal. For portable systems, the modulator can be placed near the emitter or in another convenient location. (The SS-6 Stand Kit is available for portable systems.)

POWER CONNECTION FOR U.S. APPLICATIONS:

Step 1: Connect the power supply to the 3-pin Molex connector located on the rear of the MOD 112. (See Figure 8.)

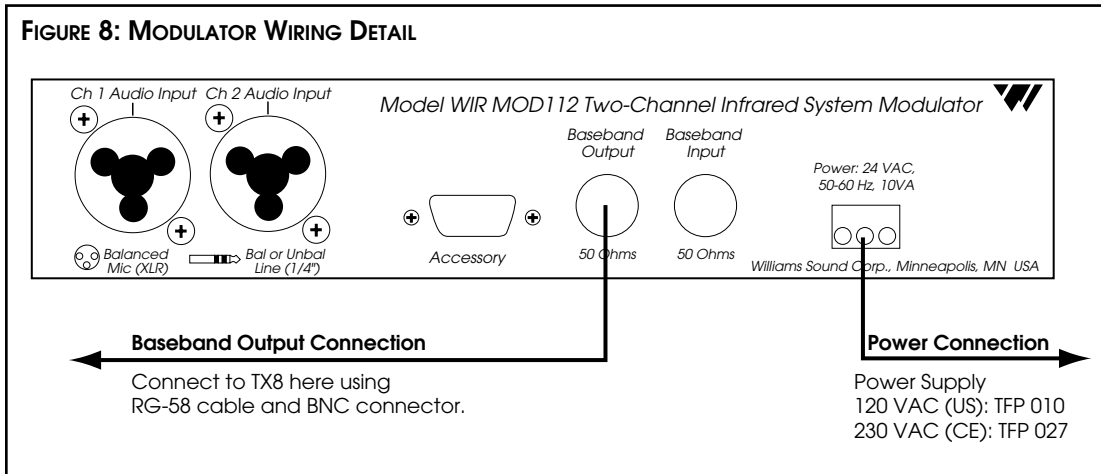

FOR APPLICATIONS OUTSIDE THE U.S. REQUIRING 240 VAC MAINS SUPPLY:

Use the wall transformer power supply, model TFP 027.

Secondary Specifications: **24 VAC, 35 VA, 50/60 Hz.**

Step 2: Plug the power supply into an AC outlet.

BASEBAND CABLE CONNECTION

The MOD 112 drives one emitter. The TX8 repeats the baseband signal, so any number of emitters can be used. The modulator outputs CANNOT be split with CATV splitters.

AUDIO CONNECTION

The MOD 112 accepts audio signals from industry-standard low impedance microphones, balanced lines, and unbalanced lines.

MICROPHONE

An industry standard 3-pin male connector is used. Pin 1 is the shield and pins 2 and 3 are audio. Power for condenser microphones is supplied according to DIN 45596.

BALANCED LINE

A 1/4 inch Tip-Ring-Sleeve (3 conductor) phone plug is used. The three-pin connectors are used for the mic input only.

UNBALANCED LINE

A 1/4 inch Tip-Sleeve (2 conductor) phone plug is used.

8 Ω speaker lines can be connected to the balanced line input. It is usually better NOT to connect to the sleeve of the plug and thus avoid creating a ground loop.

A 25 V, 70 V, or 100 V speaker line can be connected to the balanced line input using an appropriate attenuator. “T” pads made with resistors yield better fidelity than speaker matching transformers.

Note: The MOD 112 transmits audio with excellent fidelity. Therefore, be sure to connect its input to a signal source that supply the highest quality audio your system can offer. The signal should not be processed by an equalizer used for an accompanying PA system.
The MOD 112 has excellent signal processing, so the use of an additional limiter or compressor is not recommended.

INSTALLATION STEP 5: TESTING THE SYSTEM

- Step 1: After the baseband cable, power cables, and audio source are connected, turn the MOD 112 power switch on. The green power LED on the front of the MOD 112 should light.
- Step 2: Make sure the sound system is on and your audio source is active. Adjust the Audio Level Control. Check the quality of your audio source signal by listening through the Phones jack on the MOD 112’s front. The MOD 112’s 10-segment bar graph level indicator shows audio level in 3 dB steps at the input of audio level processing circuit.
- Step 3: Look at the TX8 Emitter panel(s). With the baseband signal and power connected, two red lights should be visible from directly underneath the panel: the power indicator on the right and the baseband indicator on the left. The baseband light will go off if the modulator carrier goes off—as it will after 30 minutes of no audio.
- Step 4: Hold a receiver near the “Infrared Test Out” LED on the front of the MOD 112. Turn the receiver on and adjust the volume. You should be able to hear the audio signal through the receiver. If not, make sure the “CXR On” Indicator is lit and there is activity on the Level Indicator. If the lights are not flashing, check your audio source or the setting of the input level switch and input level control. If the audio lights are flashing, but you don’t hear anything from the receiver, try a different receiver to be sure the receiver is working.
- Step 5: Take a receiver into the listening area and walk around to check the reception. Make sure the transmitter and receivers are set to the same frequency. Make sure the “eye” on the receiver is not covered up when in use. The receiver will not work if it is placed in a pocket or purse; its eye must be able to “see” the transmitter panel. Williams Sound’s optional WIRM-1 Infrared Field Strength Meter may be used to check signal strength if the system is operating on 95 kHz.

It may be necessary to adjust the angle of the transmitter to obtain the best coverage. If coverage is not adequate, add one or more WIR TX8 Transmitter panels to the system. (See page 10, *If You Are Using More Than One Emitter*)

CONTROLS AND FEATURES

MOD 112 FRONT PANEL

POWER SWITCH

Turns the entire system on and off. The associated wall mounted power supply stays on at all times and may operate continuously. There is no “wear out” mechanism.

POWER ON INDICATOR

Indicates actual operation of modulator. Does not indicate status of power supply.

LEVEL CONTROL

Controls level of audio signal. The control is connected between the input amplifier and the audio level processing circuit.

LEVEL INDICATOR

Bar graph level indicator shows audio level in 3 dB steps at input of audio level processing circuit. Indicator is peak responding and is calibrated so that optimum level is reached when the amber +3 light usually blinks and the red +6 light only blinks occasionally.

CXR ON INDICATOR

The Carrier On indicator shows when the carrier is on. The carrier comes on when power is applied, but goes off automatically if there is no audio for approximately 30 minutes. Audio sufficient to light the -21 level indicator light will reset the timer, allowing another 30 minutes before the carrier can again go off.

After the carrier has automatically gone off, audio sufficient to light the -21 level indicator light will turn the carrier back on immediately.

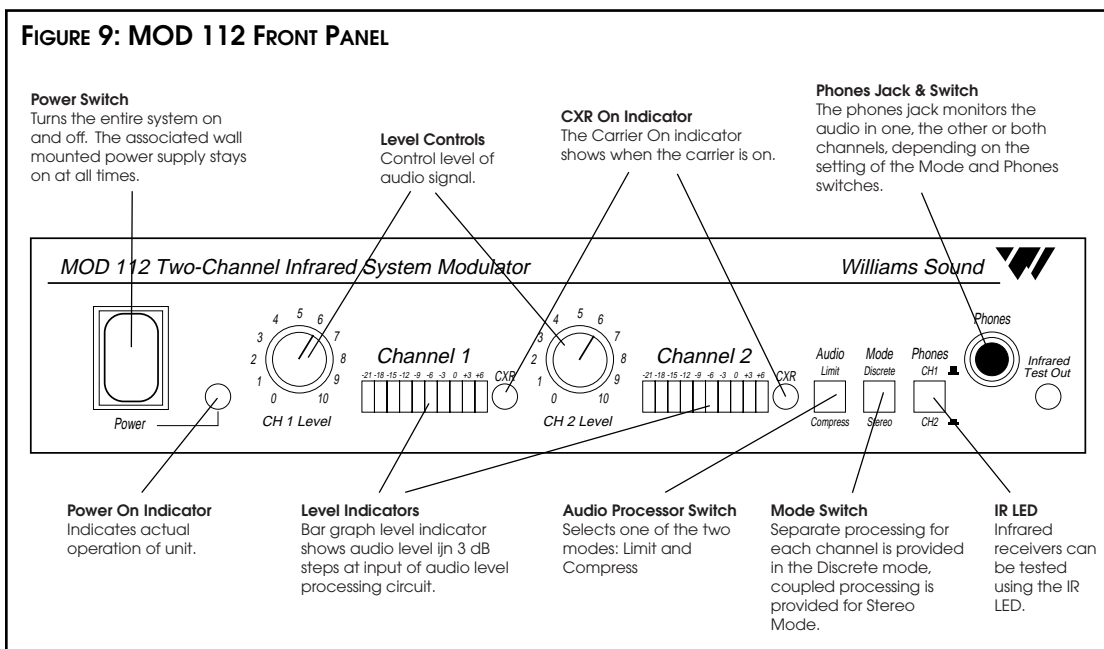



AUDIO PROCESSOR SWITCH

Selects one of the two modes available.

LIMIT MODE

The audio processor has little effect on low level sound. As the level increases, reaching the point at which the red +6 LED lights, no further increase in transmitted level is permitted. This is necessary to prevent distortion in receivers and prevent interference with other channels. Limit produces a very natural sound, and is most desirable for music. High quality speech signals are also very pleasant to listen to. However, Limit is not as helpful for hearing impaired individuals as Compress mode.

COMPRESS MODE

At high levels, 0 to +6, Compress is very similar to Limit. But at low levels Compress increases the volume substantially. Hearing impaired people need an increase in low level to be able to hear most speech.

Compress is most useful for hearing impaired individuals and in those situations where the input signal is either poorly controlled or has great dynamic range.

MODE SWITCH

The Mode Switch selects how the channels are used. Separate processing for each channel is provided in Discrete mode, where the two channels have unrelated program material such as two different languages. Coupled processing is provided for Stereo mode, where the program material is related.

DISCRETE MODE

The channels operate fully independently. Carrier timers operate separately, allowing one channel to go off without affecting the other. The Phones jack receives one or the other channel, as selected by the Phones switch. Both channels of the Phones jack have the same signal.

STEREO MODE

Audio processing is coupled, providing a consistent stereo image, important when listening with headphones. Carrier timers are coupled, requiring both to have reached approximately 30 minutes before either carrier can go off. Both carriers go off and on together. The Phones jack receives stereo sound, one channel in the left side and the other channel in the right side. The Phones switch is deactivated.

PHONES

The phones jack monitors the transmitted audio signal. It is designed to accommodate standard professional headphones with a 1/4 inch plug. It can also accept any other type of headphone or earphone. Headphones with 3.5 mm plugs can be used with a 1/4 inch to 3.5 mm adapter.

IR LED

Infrared receivers can be tested using the infrared LED. This LED is of short range only, useful to about 1 meter. The infrared signal emitted from this LED is modulated by the carriers generated in this unit only. If this modulator is connected to other modulators for additional channels, their carriers are not emitted by the LED, and must be monitored at those modulators.

MOD 112 REAR PANEL

AUDIO INPUTS 1 & 2

The MOD 112's inputs accept any low impedance microphone or line level signal. The input circuit is constructed with a "studio grade" differential amplifier, providing better performance than that available using a transformer. It is also fully protected from RFI/EMI.

MICROPHONE

Any dynamic, ribbon, or condenser microphone equipped with a balanced output and a 3 pin XLR connector can be used. Power is supplied for condenser microphones according to DIN 45596. It need not be turned off for dynamic or ribbon mics. Microphones with two conductor 1/4 inch plugs are not usable.

The minimum acceptable level is approximately 100 μ V, and the maximum level before clipping is approximately 90 mV.

LINE

Both balanced and unbalanced line level signals can be accommodated. The minimum acceptable level is approximately 100 mV, and the maximum level before clipping is approximately 10 V.

25 V, 70 V, and 100 V speaker distribution lines can be connected to the Line input using attenuators made with resistors or with speaker-matching transformers. Resistor attenuators yield better results. The minimum acceptable level is approximately 100 mV, and the maximum level before clipping is approximately 10 V.

ACCESSORY INPUT

Outputs are available directly from several points in the internal circuitry of the modulator. (See Figures 10 and 11.)

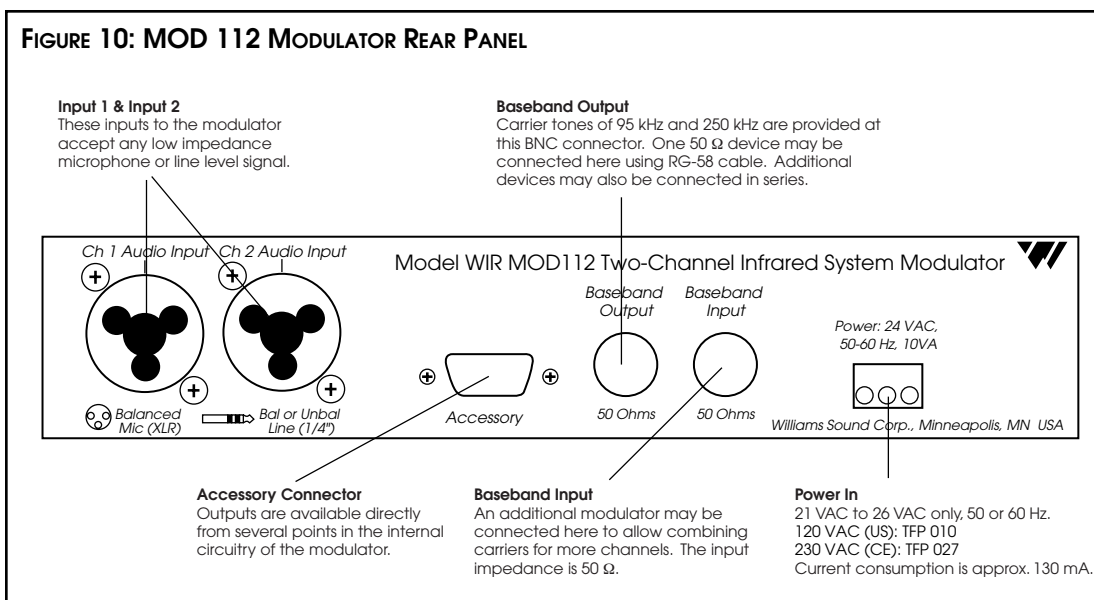
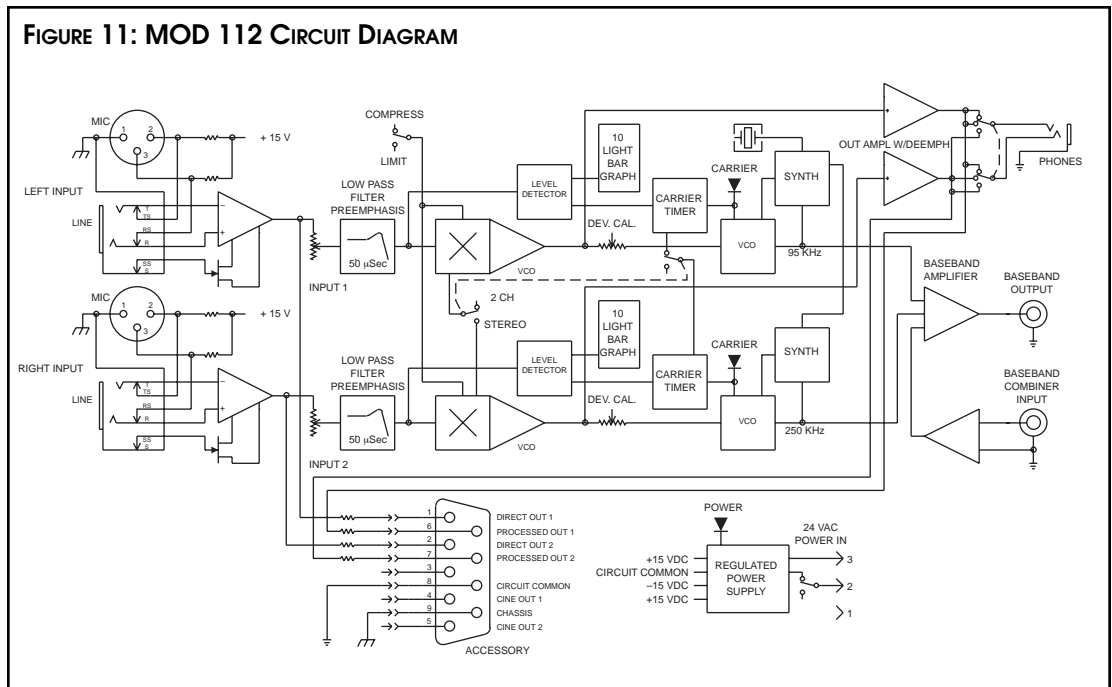

FIGURE 11: MOD 112 CIRCUIT DIAGRAM



BASEBAND OUTPUT

Carrier tones of 95 kHz and 250 kHz are provided at this BNC connector. One 50 Ω device may be connected here using RG-58 cable. Additional devices may be connected by “looping through” the connected device or by means of a suitable distribution amplifier.

The output impedance is 50 Ω. Frequency accuracy is approximately ± .005%. Deviation is ± 50 kHz, maximum. Average deviation is dependent on program material and whether Limit mode or Compress mode is selected.

BASEBAND INPUT

An additional modulator may be connected here to allow combining carriers for channels in addition to 95 kHz and 250 kHz. The input impedance is 50 Ω.

POWER IN

21 VAC to 26 VAC only, 50 or 60 Hz (TFP 016 Power Supply). Current consumption is approximately 70 mA. (TFP 027 Power Supply for 240 VAC installations)

TX8 EMITTER

POWER INPUT

Three-pin connector for TFP 010 or TFP 027 (for 240 VAC installations) power supply.

POWER INDICATOR LED

Visible through the left side of the bottom panel. Red indicator light glows when power is on.

Note: The TX8 shuts off when no baseband signal is present.

FIGURE 12: TX8 EMITTER REAR PANEL

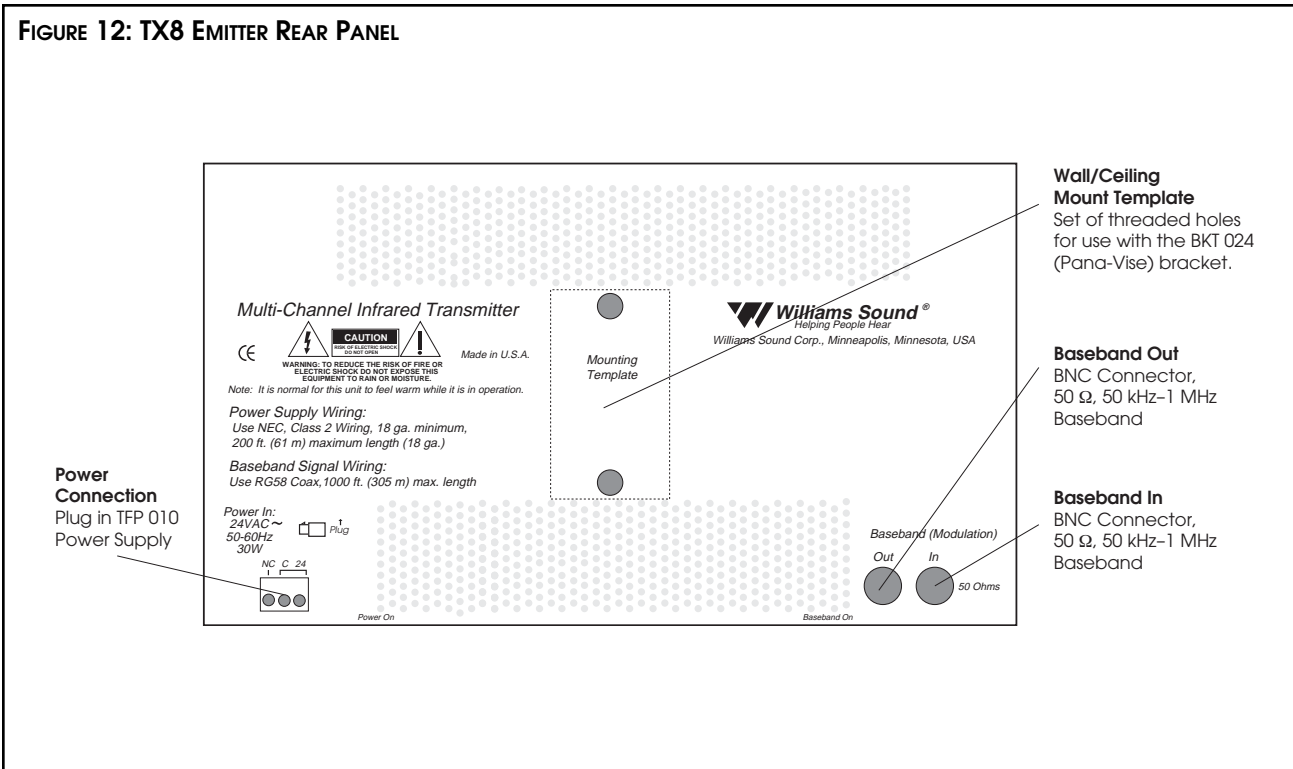

BASEBAND INDICATOR LED

Visible through the left side of the bottom panel. Red indicator light glows when power is on.

BASEBAND IN

Connects to the Baseband Out jack of the MOD 112 modulator or another TX8 emitter.

BASEBAND OUT:

Connects to the Baseband In jack of the next TX8 emitter in the chain when multiple emitters are used.

WALL/CEILING MOUNT TEMPLATE:

A mounting bracket (BKT 024) is included with the emitter. An optional tripod stand kit is also available (WSC Part #SS-6, SS-10).

Note: The WIR TX8 Infrared Emitter is a Class 1 LED product.

FIGURE 13: WIR TX8 BOTTOM PANEL

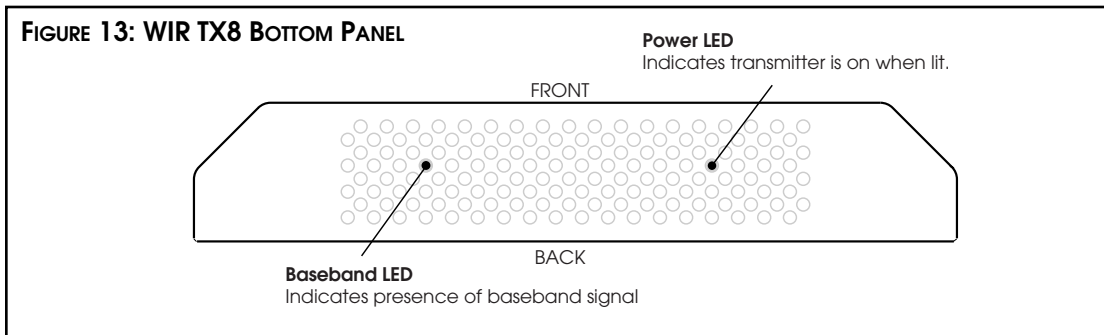

RECEIVER INSTRUCTIONS

TWO CHANNEL IR RECEIVER MODEL WIR RX5

Make sure the “eye” on the front of the receiver is not covered up when in use. The receiver is intended to be worn on the front of the body, hanging from the lanyard attached to the receiver. The receiver will not work if it is placed in a pocket or purse. A variety of earphones, headphones, or a neckloop telecoil coupler can be used with the RX5 Receiver.

- Step 1: To install the batteries, open the battery compartment using a coin in the slot in the bottom of the receiver. Press two AA batteries into place, observing proper battery polarity.
- Step 2: Plug the earphone or headphone into the earphone jack.
- Step 3: Turn the receiver on by rotating the volume control knob clockwise.
- Step 4: Choose the appropriate channel using the push-button channel selector.
- Step 5: Adjust the tone to your preference using the slide switch tone control. To avoid draining the battery, make sure the receiver is turned off when not in use.

STEREO IR RECEIVER MODEL WIR RX6

Make sure the “eye” on the front of the receiver is not covered up when in use. The receiver is intended to be worn on the front of the body, hanging from the lanyard attached to the receiver. The receiver will not work if it is placed in a pocket or purse.

A variety of stereo earphones and headphones can be used with the RX6 Receiver.

- Step 1: To install the batteries, open the battery compartment using a coin in the slot in the bottom of the receiver. Press two AA batteries into place, observing proper battery polarity.
- Step 2: Plug the earphone or headphone into the earphone jack.
- Step 3: Turn the receiver on by rotating the volume control knob clockwise.
- Step 4: Adjust the tone to your preference using the slide switch tone control. To avoid draining the battery, make sure the receiver is turned off when not in use.

!! IMPORTANT WARNINGS !!

DO NOT ATTEMPT TO RECHARGE ZINC CARBON (“HEAVY DUTY”), ALKALINE, OR LITHIUM BATTERIES!

DO NOT ATTEMPT TO RECHARGE SINGLE-USE BATTERIES! These batteries may heat up and explode, causing possible injury and damage to the equipment.

Avoid shorting the plus and minus battery terminals together with metal objects. Battery damage and burns can result!

Use only Williams Sound supplied chargers and batteries!



BATTERY INFORMATION

For RX5 and RX6 Receivers in normal use, a AA alkaline battery (BAT 001) will last about 30 hours. Rechargeable AA batteries will last about 15 hours per charge.

If you are using BAT 026 rechargeable batteries, use the CHG 200A Multi-Charger. Contact your dealer or Williams Sound for details.

If the sound becomes weak or distorted, replace the batteries. The indicator light may still be on, even with weak batteries. Do not leave dead batteries in the receiver, they may leak and damage the receiver.

RECEIVER MANAGEMENT

Different types of facilities will use different approaches for receiver management and earphone sanitation. Below are some options that customers have used successfully.

- ▶ Regular users purchase their own receiver and take care of their own batteries and earphone.
- ▶ Some facilities label the receiver and earphone with the names of regular users so each person uses the same receiver and earphone.
- ▶ Ushers issue receivers to people who request them. Earphones are sanitized after use. Foam ear cushions can be replaced or washed with a mild detergent, rinsed thoroughly and air-dried. The EAR 022 Surround Earphone can be sanitized with an alcohol pad.
- ▶ The receivers can be stored in a multiple compartment storage case with a credit card or driver's license left as collateral for the receiver.
- ▶ Regular users purchase their own earphone or headphone and bring them to use with receivers at the facility.
- ▶ Some facilities use the drop-in style CHG 200 Multi-charger for both storing and charging receivers.

TROUBLESHOOTING

NEITHER TX8 INDICATOR LIGHT IS ON (FIGURES 1A AND 13).

- ▶ Make sure the wall transformer is plugged into the emitter and the power switch or any remote power switch is on.
- ▶ Make sure the electrical outlet is on.
- ▶ Make sure the 24 VAC power supplies are working.

ONLY TX8'S POWER INDICATOR LED COMES ON (FIGURES 1A AND 13).

- ▶ Make sure the MOD 112 is on.
- ▶ Make sure the baseband cable is connected properly.
- ▶ Check to see if the carrier light on the MOD 112 is on.
- ▶ Make sure an audio signal is being sent to the MOD 112.

NO SOUND THROUGH RECEIVERS.

- ▶ If some of the receivers work but others don't, check for bad batteries or earphones on the receivers that aren't working.
- ▶ If none of the receivers work, check to see if the power and baseband cable are connected to the emitter and that the Power and Baseband Present Indicator lights are ON.
- ▶ Check to see if the modulator is connected properly to the sound system. The CXR On Indicator should be lit and there should be activity on the MOD 112's Level Indicators.
- ▶ Make sure the "eye" is not covered up on the receiver. There must be clear line of sight between the receiver eye and the emitter panel.

SOUND THROUGH THE RECEIVERS IS WEAK AND NOISY.

- ▶ Hold a receiver in front of the Infrared Test LED on the front of the MOD 112 modulator and listen to the signal. If the signal is weak and noisy here, check the Input Level switch and Input Level Control settings. Increase the input signal level from the sound system by turning up a mixer control. If the signal sounds okay, you may need to re-position the emitter panels or add additional panels.
- ▶ *NOTE: Make sure the powerline voltage does not fall below 94V, or system performance will be greatly reduced!*

BUZZING OR HUMMING NOISE IN SOUND SYSTEM.

- ▶ Check for ground loops or noise on the input signal. Call your Authorized Dealer or Williams Sound for help.



WARRANTY

Williams Sound emitters and receivers are warranted against defects in workmanship and materials for FIVE YEARS. Microphones, earphones, cables, carry cases, rechargeable batteries and chargers are warranted against defects in workmanship and materials for 90 DAYS.

This warranty does not extend to intentional or accidental physical damage. This warranty applies only to products returned to Williams Sound for service. To return a product for service, call the phone number below and request a Return Authorization (RA) number.

Williams Sound Corp.
10399 West 70th Street
Eden Prairie, MN 55344-3459 USA

Phone: 800-843-3544
952-943-2252

Fax: 952-943-2174

TTY: 952-943-9675

Web: www.williamssound.com
info@williamssound.com

SoundPlus® WIR TX800 Infrared System Specifications

TWO-CHANNEL INFRARED MODULATOR, MODEL MOD 112

Dimensions, Weight:	8.45" (21.5 cm) W x 8.18" (20.8 cm) D x 1.72" (4.4 cm) H, 3 lbs. (1.4 kg)
Color:	Black epoxy paint with white legends
Rack Mount:	One IEC rack space high, one or two units can be mounted in a single rack space with optional RPK 005 (single) or RPK 006 (double) Rack Mount Kits
Power:	External power supply, 24 VAC, 50 or 60 Hz, 10 VA maximum
Baseband Output:	50 Ω source impedance
Carriers:	100 mV per carrier Channel 1: 95 kHz \pm 50 kHz deviation, 50 μ sec pre-emphasis Channel 2: 250 kHz \pm 50 kHz deviation, 50 μ sec pre-emphasis
AGC:	Variable slope compressor or soft limiter, switch selected
Carrier Timers:	One 30 minute (approx.) timer per channel. Turns off carrier if channel is silent (lowest light on bar graph does not light) for approximately 30 minutes.
Operating Requirements:	0-50°C ambient temperature, non-condensing, non-corrosive atmosphere

FRONT PANEL:

Power Switch:	Two-position rocker, ON/OFF
Power Indicator:	Green LED
Audio Level Controls:	1 rotary control per channel
Audio Indicators:	One (1) 10 LED bar graph per channel
Carrier (CXR) LEDs:	1 green carrier "on" indicator LED per channel
Limit/Compress Switch:	Selects variable slope compression or soft limiting
Stereo/Discrete Switch:	Selects stereo (coupled processing and timers, stereo monitoring) or discrete (Independent processing and timers, mono monitoring)
Phones Switch:	Selects CH 1 or CH 2 for phones when mode is in discrete position
Phones Output:	1/4" stereo phones jack. Produces stereo or mono output depending on modulation mode selected. Accepts stereo, mono, and any impedance phones.
Infrared Test LED:	IR LED for receiver testing, monitoring, and audio signal testing.

REAR PANEL:

Mic Input:	Combination jack, 3 pin XLR, balanced, lo-Z, 100 μ V min. to 90 mV max. 1m V nominal, 3 k Ω input impedance. Supplies simplex power 20 V (DIN45596) for condenser mics
Line Input:	Combination jack, 1/4" TRS jack. 21 mV min. to 10 V max., 212 mV nominal, 100 K Ω input impedance. Accepts unbalanced or balanced line level inputs
Baseband Output:	(1) BNC connector, 50 Ω , 100 mV RMS per carrier, use RG-58 cable
Baseband Loophru Input:	(1) BNC connector, 50 Ω
Power Connections:	3-pin molex
Emitter Type:	For use with Williams Sound Infrared Emitters. For multi-emitter systems, each emitter repeats the baseband signal to drive the next emitter in the chain.
Accessory Connector:	9-pin, Sub-D female, various circuit connections (See diagram on top panel and in manual for details)

MULTI-CHANNEL INFRARED EMITTER, MODEL TX8

Dimensions, Weight:	11.25" W x 6.25" H x 2.125" D (28.6 cm x 15.9 cm x 5.4 cm) 1.9 lbs. (0.9 kg)
Color:	Black epoxy paint with white legends, red acrylic window
Wall Mount:	BKT 024 mounting bracket included for wall and ceiling mounting.
Tripod Mount:	Optional SS-6 Tripod Stand Kit available
Power:	External power supply, 24 VAC, 50 or 60 Hz, 50 VA, 0.9 A nom. current drain Emitter shuts off when baseband signal is not present
Operating Req.:	0-50° C ambient temperature, non-condensing, non-corrosive atmosphere
Coverage Area:	Two-Channel mode: 3,760 sq. ft. (350 sq. m) Single-Channel mode: 10,000 sq. ft. (930 sq. m) 50° cone pattern, see coverage diagrams
Infrared Type:	Class 1 LED Product

FRONT PANEL:

Power Indicator:	Red LED, visible from bottom through vent holes, lower right
Baseband Indicator:	Red LED, visible from bottom through vent holes, lower left

REAR PANEL:

Mounting Holes:	One set of threaded holes for use with the BKT 024 mounting bracket (included) Two threaded holes on sides of the cabinet for Tripod Stand Kit
Baseband Input:	BNC connector, 50 Ω , 50 kHz to 500 kHz carriers, 100 mV nominal per carrier, 10 V RMS maximum aggregate baseband amplitude
Baseband Output:	BNC connector, 50 Ω , 50 kHz to kHz baseband
Baseband Cable:	RG-58 Coax, BNC-connectors
Power:	External power supply, 3-pin molex connector, 24 VAC, 50 or 60 Hz, 30 VA, 0.9 A nom. current drain
Power Cable:	NEC Class 2 wiring, 2-conductor, 18 ga.; 200 foot (61 m) max. length for 18 gauge wire (See table below for minimum gauge requirements at other lengths) Each TX8 Transmitter requires its own 24 VAC Power Supply

<u>Cable Length Required</u>	<u>Minimum Wire Gauge</u>
Up to 10 feet (3 m)	22 gauge
Up to 75 feet (23 m)	20 gauge
Up to 200 feet (61 m)	18 gauge
Up to 500 feet (152 m)	16 gauge
Up to 1,000 feet (305 m)	14 gauge

TWO-CHANNEL INFRARED RECEIVER, MODEL WIR RX5

Size and Weight:	3-5/8" L x 2-3/8" W x 7/8" H (9.2 cm x 6 cm x 2.4 cm)
Color and Material:	Gray, shatter-proof polypropylene
Battery Type:	1.5V (AA) x 2, Alkaline (BAT 001) or Rechargeable AA NiMH (BAT 026)
Battery Life:	30 hours with BAT 001, 15 hours/charge with BAT 026, 25 mA, nom. current drain
Modulation Frequencies:	95 kHz FM, 50 μ S de-emphasis OR 250 kHz FM, 50 μ S de-emphasis
Signal to Noise Ratio:	60 dB with WIR TX8
Controls:	Combination volume/On-Off knob, Push-button channel selector, Switched Low-Cut tone control Lo: 20 Hz / Mid: 120 Hz / Hi: 700 Hz
Audio Output:	3.5 mm mono mini phone jack, 35 mW maximum into 16 Ω
Acoustic Output:	130 dB MAX SSPL90 with EAR 013 The RX5 Two-Channel Infrared Receiver can be used with a Neckloop TeleCoil Coupler (NKL 001) to magnetically couple into a hearing aid that has a telephone pick-up coil.

STEREO INFRARED RECEIVER, MODEL WIR RX6

Size and Weight:	3-5/8" L x 2-3/8" W x 7/8" H (9.2 cm x 6 cm x 2.2 cm)
Color and Material:	Gray, shatter-proof polypropylene
Battery Type:	1.5V (AA) x 2, Alkaline (BAT 001) or Rechargeable AA NiMH (BAT 026)
Battery Life:	30 hours with BAT 001, 15 hours/charge with BAT 026, 25 mA, nom. current drain
Modulation Frequencies:	95 kHz FM, 50 μ S de-emphasis AND 250 kHz FM, 50 μ S de-emphasis
Signal to Noise Ratio:	60 dB with WIR TX8
Controls:	Combination volume/On-Off knob, Switched Low-Cut tone control (Lo: 20 Hz / Mid: 120 Hz / Hi: 700 Hz)
Audio Output:	3.5 mm stereo mini phone jack, 35 mW maximum into 16 Ω
Acoustic Output:	130 dB MAX SSPL90 with EAR 014

ACCESSORIES

CHG 200 Multi-Charger	This charger is designed to store and charge one or two receivers simultaneously overnight. 110 VAC
SS-6 Tripod Stand Kit	Includes adjustable tripod stand, adaptor, mounting bracket, and hardware. Mounts modulator and emitter together or separately.
RPK 005/RPK 006 Rack Panel Kits	The RPK 005 mounts one modulator in one EIA rack space, the RPK 006 mounts two. Includes all necessary hardware and easy-to-follow instructions.